

INSTALLATION INSTRUCTIONS FOR COA-42800 TF-727 BOLT-IN SPRAG

Thank you for purchasing a Coan Racing performance product. For over 25 years Coan Engineering has been the leader in hi-performance race transmissions and converters. Our ongoing research and development assures that you have purchased the best products available.

*** COMMITMENT * PERFORMANCE * RELIABILITY ***
*** A WINNING COMBINATION ***

Kit Includes:

- Bolt-in style cam/w Spring Retainer
- Spring and Roller Kit
- 4 - 8mm X 30mm-M6X1 (Requires 4mm Allen wrench) shoulder bolts
- 4 - 5/16" Flat Washers and 4 - 5/16" Lock Washers

This bolt-in one-way clutch is a direct replacement for the OEM press in roller. Installation of this kit will require complete disassembly of the transmission and should be performed by an experienced transmission technician.

1. Once the transmission is completely disassembled, the existing cam must be removed from the case by inserting a punch through one of the rear support boltholes and tapping. Alternate between the four rear support holes to evenly tap the cam out of the case. Your new cam will be retained in the case by using the four rear support boltholes in addition to a press fit on its outer diameter.
2. The existing rear support boltholes must be enlarged to accommodate the shoulder bolts, which will be used to accurately retain both the cam and the rear support. Using a 8 mm preferred or 21/64" drill, enlarge the four existing holes in the case making sure to drill them as straight as possible. If these holes are not straight, the shoulder bolts will not be aligned properly and may not thread into the cam. (FIGURE 1)
3. Once the holes are enlarged, the cam may be installed into the case. The outer diameter has a lead machined on the serrations to aid installation. (FIGURE 2)
4. Install this lead towards the rear of the case, making sure each of the four holes are aligned. (FIGURE 3)

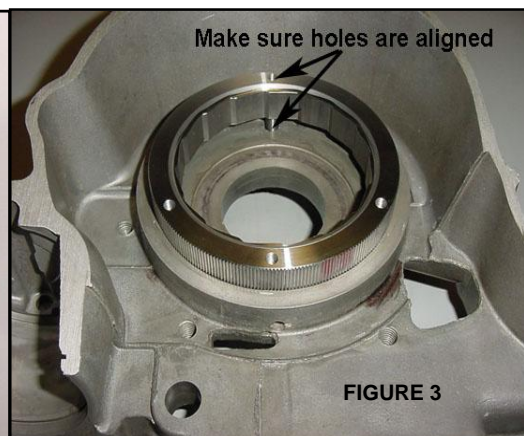
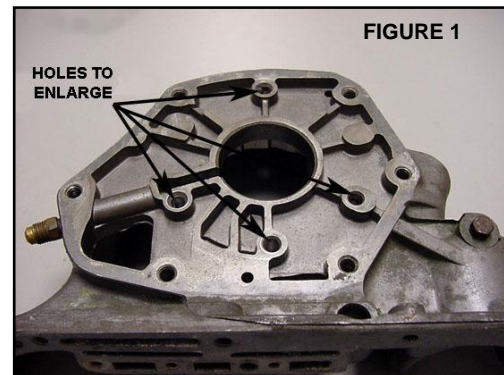

5. Confirm proper alignment by threading each of the four bolts into the cam (without the rear support installed). (FIGURE 4)
6. Use the four bolts to begin drawing the cam into the case by alternately snugging each and then tapping on the cam with a hammer (DO NOT USE A METAL HAMMER DIRECTLY ON THE CAM, USE EITHER A RUBBER Mallet, BRASS HAMMER/PUNCH). As the cam begins to move in the case, keep alternately tightening the four bolts.
7. Be certain that the cam is fully installed and sits flat against the back of the case. If so, remove the four shoulder bolts.
8. Now the rear support may be installed and retained to the case by reinstalling the four shoulder bolts, using 2 washers under the head of each. Tighten the bolts to 100 inch-lbs. (FIGURE 5)
9. The final step is assembly of the roller clutch. Place the inner race in the center of the retainer and install the rollers such that the springs preload them against the lobes of the cam. (FIGURE 6)

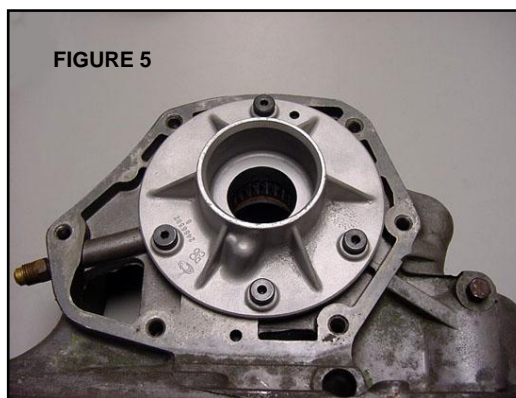
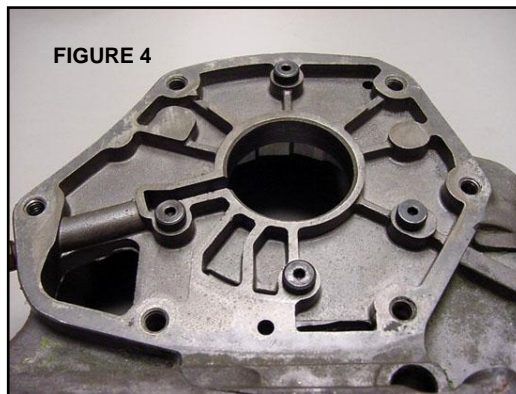

If you have any questions regarding the proper installation and/or operation of a Coan Racing product, please call (765) 456-3957. You may also fax us at (765) 456-3960, or e-mail at coan@coanracing.com.

Warranty

Coan Engineering offers a limited warranty covering all new products for ninety days and all repair service for thirty days from the original date of purchase to be free from flaws in material and craftsmanship. The warranty is non-transferable. Under no circumstances will Coan Engineering extend its warranty to products, new or repaired, which have been abused, misused, or incorrectly installed. Disassembly of any product by means other than a Coan Engineering technician will void any potential warranty. All warranty claims must be accompanied by the original invoice and are subject to the approval of Coan Engineering.

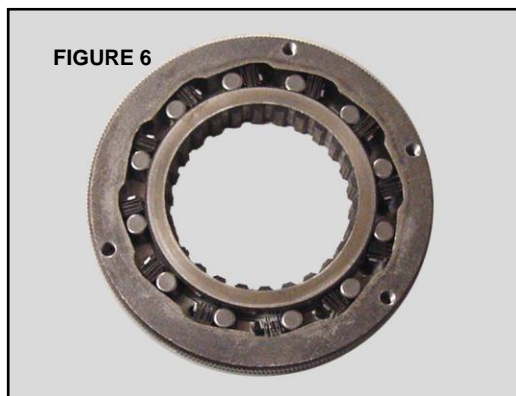

The above stated warranty **does not include** any shipping charges or labor charges for installation or removal of any Coan Racing product.

Liability

In no manner, neither written nor implied, does Coan Engineering accept liability for consequential or incidental damages to person or property resulting from the use or misuse of its products. Product failure occurring within the stipulations of the warranty policy will be dealt with explicitly under those particular guidelines.

