

INSTALLATION INSTRUCTIONS 700R4 AND 2004R NON-LOCK UP CONVERTER CLUTCH VALVE PART #92847

Thank you for purchasing a Coan Racing performance product. For over 25 years Coan Engineering has been the leader in hi-performance race transmissions and converters. Our ongoing research and development assures that you have purchased the best products available.

*** COMMITMENT * PERFORMANCE * RELIABILITY ***
*** A WINNING COMBINATION ***

COMPONENTS

- (1) Aluminum Plug
- (1) 5/16x18 Set Screws

1. Remove stock lock-up valve and springs, parts: #227, #228, and #229. (figure A)
2. Drive out cup plug located in position #25 in pump. (figure B)
3. Tap hole #25 5/16 x 18 through to valve bore.
4. Insert non-lockup valve as shown, with the side with two holes placed outward toward the outer edge of the pump.(figure A)
5. Install valve stop and snap ring. #226 & #225 (figure A)
6. Put a few drops of loc-tite on set screw and screw in hole #25. Tighten until valve is locked into place.
7. Lock-up solenoid may be disconnected, but must be left in the stock location.
8. **Remove check ball and capsule** from the end of the input shaft. (figure C)

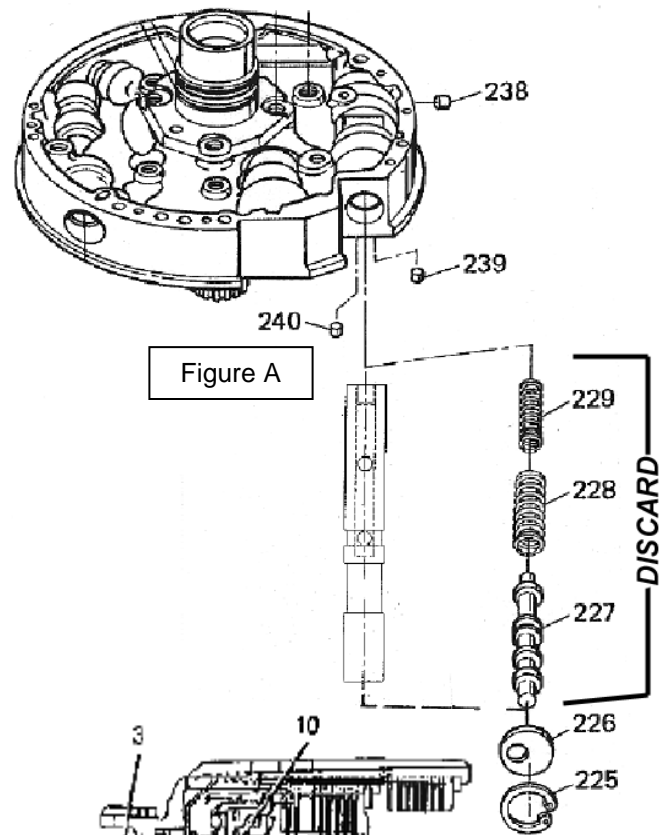
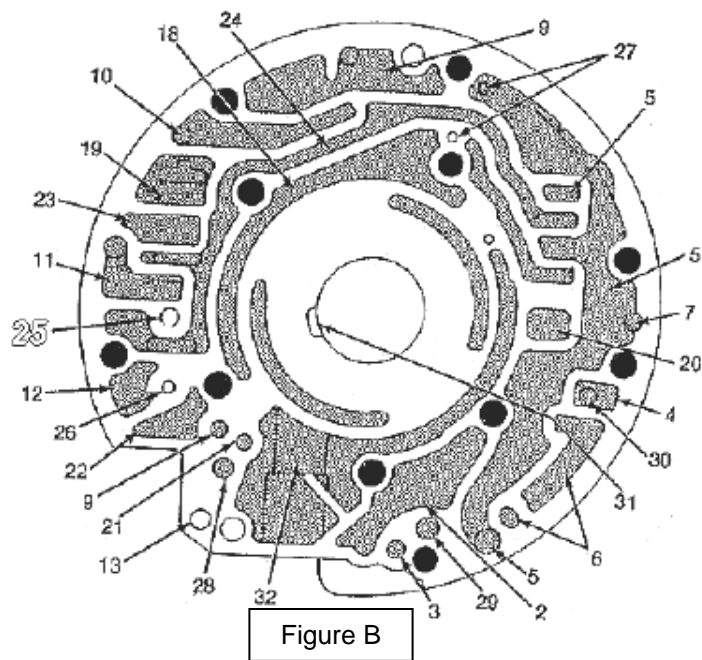

If you have any questions regarding the proper installation and/or operation of a Coan Racing product, please call (765) 456-3957. You may also fax us at (765) 456-3960, or e-mail at coan@coanracing.com.

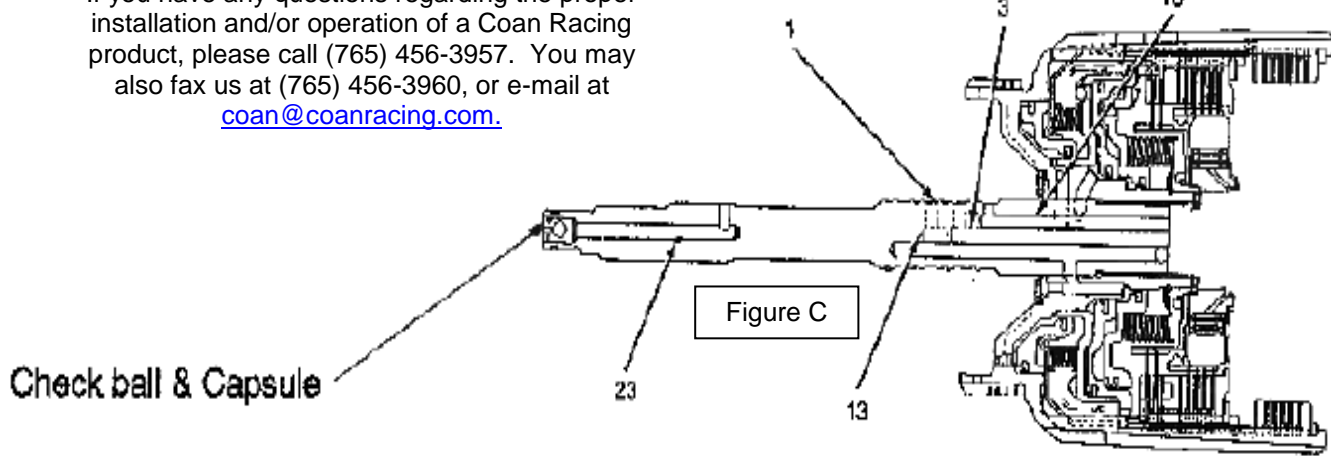

Warranty

Coan Engineering offers a limited warranty covering all new products for ninety days and all repair service for thirty days from the original date of purchase to be free from flaws in material and craftsmanship. The warranty is non-transferable. Under no circumstances will Coan Engineering extend its warranty to products, new or repaired, which have been abused, misused, or incorrectly installed. Disassembly of any product by means other than a Coan Engineering technician will void any potential warranty. All warranty claims must be accompanied by the original invoice and are subject to the approval of Coan Engineering.

The above stated warranty **does not include** any shipping charges or labor charges for installation or removal of any Coan Racing product.

Liability

In no manner, neither written nor implied, does Coan Engineering accept liability for consequential or incidental damages to person or property resulting from the use or misuse of its products. Product failure occurring within the stipulations of the warranty policy will be dealt with explicitly under those particular guidelines.