

Adapter Plate B.O.P. Trans. To Chevy Engine Part#980074

The Adapter Plate kit will allow you to use a Buick, Pontiac, Oldsmobile and Cadillac 350 and 400 Transmissions. No alterations are necessary and installation is easy and simple.

NOTE: On some Turbo 400 Transmissions, the inside webbing located inside the bell housing may interfere with two of the adapter plate kit bolts. Webbing must be trimmed to clear these bolts.

Part#980074 Kit Contains:

Qty Description

Four (4) 3/8" X 3/4 Button Head Cap Screws

One (1) Adapter Plate

Three (3) 1/8" Converter Spacers

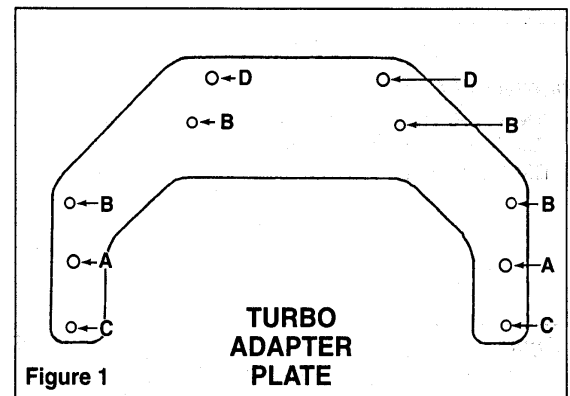

Figure 1

Step 1 Position the (E) adapter plate on the back of the engine with the attached nuts facing the engine. Align the "A" holes on the adapter plate over the engine dowel pins. (See **Figure 1** for location).

Step 2 In the boltholes marked "B" use the four (4) bolts supplied to secure the adapter to the engine. All engine bolts should be torqued to 35 foot pounds.

Step 3 Install converter and transmission using two (2) OEM bolts location "D" on the adapter plate. Use OEM bolts in location "C". All engine bolts are torque to 35 foot pounds.

Step 4 Before bolting the converter to the flywheel; use a spacer between the converter and fiexplate. Torque flywheel/converter bolts to 30 foot pounds. Converter "Pull Back" to the flywheel should be between 1/8" to 3/16" with the spacers.

IMPORTANT -SEE BACK FOR ADDITIONAL INFORMATION.



"A" MUST BE GREATER THAN "B"

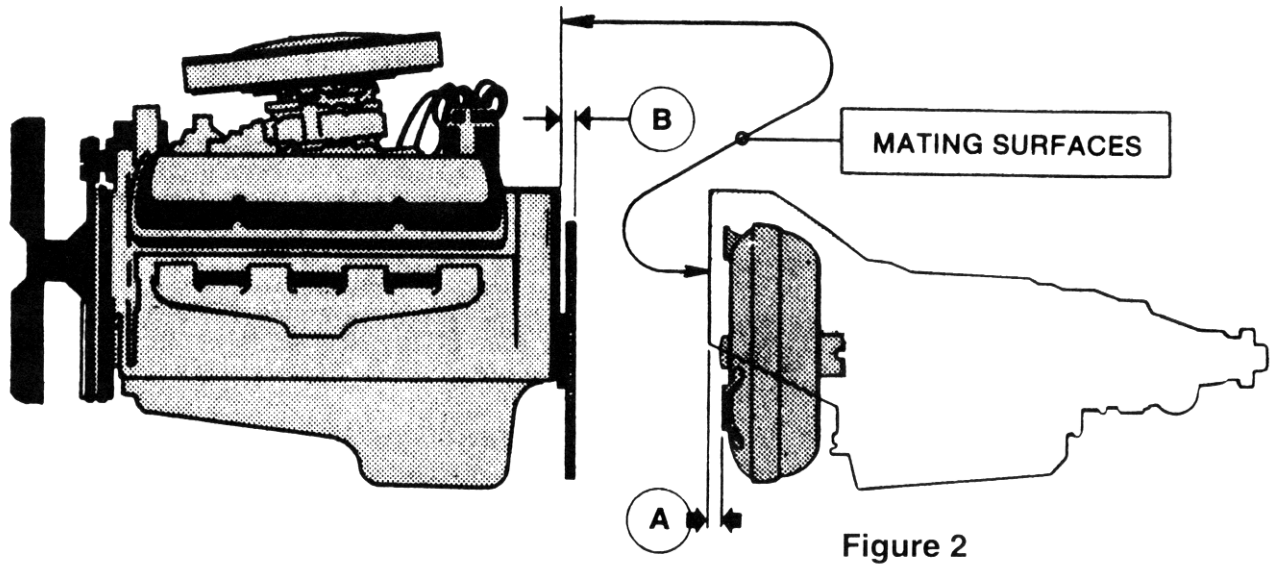

Figure 2

DEPTH CLEARANCE:

TH350 - 1-1/8" from Bell Housing to Pads

TH400 - 1-3/16" from Bell Housing to Pads

Powerglide - 1" from Bell Housing to Pads

*Distance may vary either way .050"

Figure 3

Measure the depth of mounting pad face (A) from the mounting flange face. Notice that the right hand that is holding the straight edge is also pushing the converter in toward the transmission.

*Distance may vary either way .050"

The finger points to the front pump seal, which wipes the h a qualified source.

Figure 3

